

MB-S18 S4

MB[®]
THE CRUSHING EVOLUTION

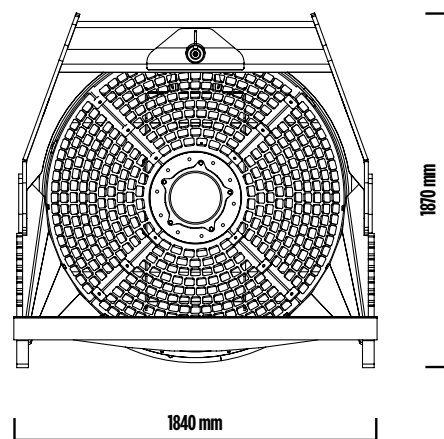

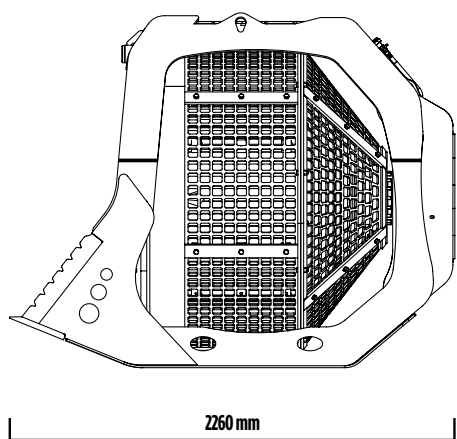

MB-S18 S4

The MB-S18 screening bucket has been designed for medium and large-scale contexts that require high performance and large-scale production. This model is fitted with a metal separator that allows the rapid and efficient separation of iron from the material screened, as well as a spray for the reduction of dust resulting from operations.

PRIMARY SELECTION:

WASTE MATERIAL
DEMOLITION MATERIAL
EXCAVATION FILLING MATERIAL
PEBBLES IN STREAMS
DEBRIS IN BEACHES
NATURAL STONES CLEANING

ACCESSORIES

RECOMMENDED SPARE PARTS KIT
FIXED COUPLER
QUICK FEMALE COUPLER
IRON SEPARATOR
DUST SUPPRESSION KIT
HOUR METER
24 MONTHS WARRANTY

AREAS OF APPLICATION

RECYCLING
PIPING
LARGE-SCALE URBAN SITES
QUARRIES
MINES

SPECIFICATIONS

EQUIPMENT	LOAD CAPACITY	BASKET DEPTH	GRID DIAMETER	DIMENSIONS
≥ 20 < 35 Ton	2,40 m ³	1220 mm	1600 mm	2260 x 1840 H 1870 mm
OIL FLOW	PRESSURE	COUNTER PRESSURE DRAIN	WEIGHT	SPEED/MIN.
120 l/min.	200 bar	-	2 Ton	15/25 min/max