

MB-LS170

MB[®]
 THE CRUSHING EVOLUTION

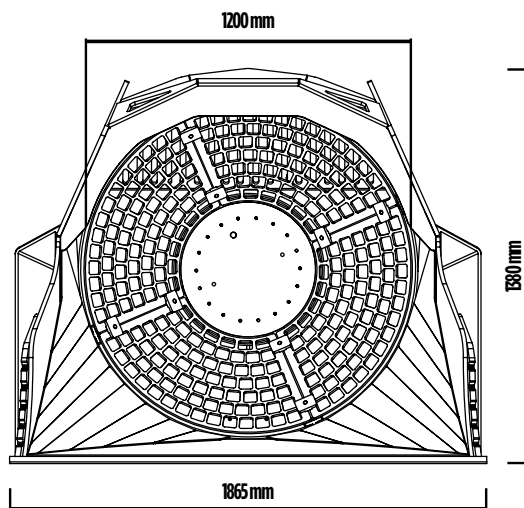

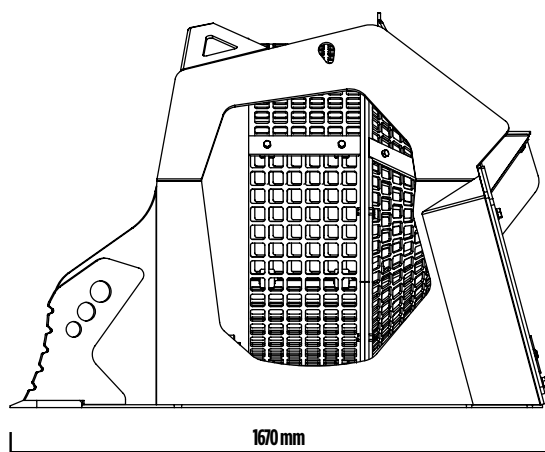
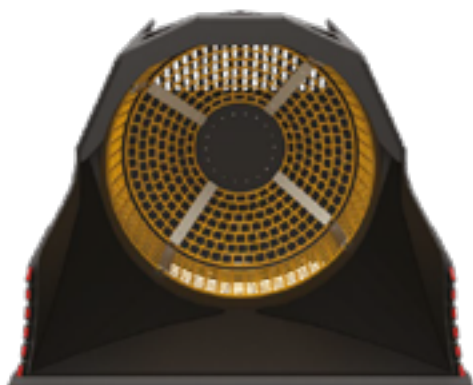

MB-LS170

The MB-LS170 screening bucket has been designed to be used with excavators, mini-excavators and loaders. Combined usage with Mb crusher buckets allows for a reduction of up to 60% in terms of crushing time, immediately recycling desired size materials.

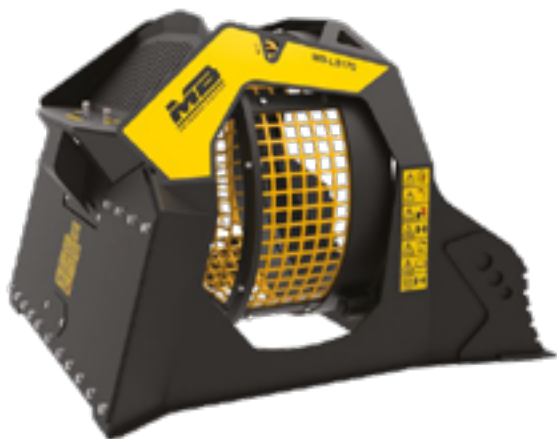

PRIMARY SELECTION:

- WASTE MATERIAL
- DEMOLITION MATERIAL
- EXCAVATION FILLING MATERIAL
- STONY GROUND RECLAIM
- PEBBLES IN STREAMS
- DEBRIS IN BEACHES
- NATURAL STONE S CLEANING

ACCESSORIES

- RECOMMENDED SPARE PARTS KIT
- HOUR METER
- 24 MONTHS WARRANTY

AREAS OF APPLICATION

- RECYCLING
- MEDIUM-SCALE RESIDENTIAL WORKSITES
- SMALL-SCALE COMMERCIAL WORKSITES
- DEMOLITION

SPECIFICATIONS

EQUIPMENT	LOAD CAPACITY	BASKET DEPTH	GRID DIAMETER	DIMENSIONS
 ≥ 6,5 ≤ 11 Ton	1,10 m ³	890 mm	1200 mm	1670 x 1865 H 1380 mm
OIL FLOW	PRESSURE	COUNTER PRESSURE DRAIN	WEIGHT	SPEED/MIN.
60 l/min.	150 bar	-	1,35 Ton	15/25 min/max